

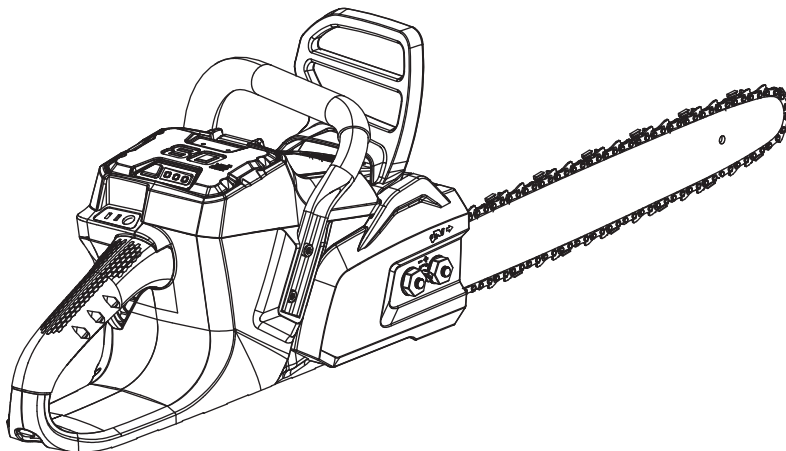

greenworks™

80V CORDLESS BRUSHLESS CHAINSAW

GCS80421
2000002



Some Greenworks Lithium-Ion products are sold with or without battery and charger.

To order: Battery (2Ah 80V Battery 2901302)
Charger (Model # 2901402)



Owner's Manual

TOLL-FREE HELPLINE: 1-888-90WORKS (888.909.6757)

www.greenworkstools.com

 Read all safety rules and instructions carefully before operating this tool.

CONTENTS

Contents	1
Product specifications.....	1
Safety information.....	2-7
Symbols.....	8-9
Know your chain saw	10
Assembly	11
Operation.....	12-26
Maintenance	27-36
Environmentally safe battery disposal	37
Troubleshooting	38
Warranty	39
Exploded View	40
Parts List.....	40

PRODUCT SPECIFICATIONS

80V CORDLESS BRUSHLESS CHAINSAW

Type.....	Cordless, battery-powered
Motor	80 V
Bar length	18" (45.8cm)
Chain pitch	3/8" (9.5 mm)
Chain gauge005" (1.1 mm)
Chain type91P062X
Guide bar type.....	180SDEA041
Unit weight (without battery).....	11 lbs (4.98 kg)
Unit weight (with 2Ah battery).....	14.2 lbs (6.44 kg)



IMPORTANT SAFETY INSTRUCTIONS

WARNING

Read all safety warnings designated by the symbol  and all instructions. Failure to follow the warnings and instructions may result in electric shock, fire and/or injury.

READ ALL INSTRUCTIONS.

The term “power tool” in all of the warnings refers to your mains-operated (corded) power tool or battery-operated (cordless) power tool.

1. Work area safety

- A. Keep work area clean and well lit. Cluttered or dark areas invite accidents
- B. Do not operate power tools in explosive atmospheres, such as in the presence of flammable liquids, gases or dust. Power tools create sparks which may ignite the dust or fumes.
- C. Keep children and bystanders away while operating a power tool. Distractions can cause you to lose control.

2. Electrical safety

- A. Power tool plugs must match the outlet. Never modify the plug in any way. Do not use any adapter plugs with earthed (grounded) power tools. Unmodified plugs and matching outlets will reduce risk of electric shock.
- B. Avoid body contact with earthed or grounded surfaces such as pipes, radiators, ranges and refrigerators. There is an increased risk of electric shock if your body is earthed or grounded.
- C. Do not expose power tools to rain or wet conditions. Water entering a power tool will increase the risk of electric shock.
- D. Do not abuse the cord. Never use the cord for carrying, pulling or unplugging the power tool. Keep cord away from heat, oil, sharp edges or moving parts. Damaged or entangled cords increase the risk of electric shock.
- E. When operating a power tool outdoors, use an extension cord suitable for outdoor use. Use of a cord suitable for outdoor use reduces the risk of electric shock.
- F. If operating a power tool in a damp location is unavoidable, use a residual current device (RCD) protected supply. Use of an RCD reduces the risk of electric shock.

NOTE: The term “residual current device (RCD) may be replaced by the term “ground fault circuit interrupter (GFCI) or (earth leakage circuit breaker (ELCB)”.

3. Personal safety

- A. Stay alert, watch what you are doing and use common sense when operating a power tool. Do not use a power tool while you are tired or under the influence of drugs, alcohol or medication. A moment of inattention while operating power tools may result in serious personal injury.
- B. Use personal protective equipment. Always wear eye protection. Protective equipment such as dust mask, non-skid safety shoes, hard hat, or hearing protection used for appropriate conditions will reduce personal injuries.
- C. Prevent unintentional starting. Ensure the switch is in the off-position before connecting to power source and/or battery pack, picking up or carrying the tool. Carrying power tools with your finger on the switch or energizing power tools that have the switch on invites accidents.
- D. Remove any adjusting key or wrench before turning the power tool on. A wrench or a key left attached to the power tool may result in personal injury.
- E. Do not overreach. Keep proper footing and balance at all times. This enables better control of the power tool in unexpected situations.

IMPORTANT SAFETY INSTRUCTIONS

F. Dress properly. Do not wear loose clothing or jewelry. Keep your hair, clothing and gloves away from moving parts. Loose clothes, jewelry, or long hair can be caught in moving parts.

G. If devices are provided for the connection of dust extraction and collection facilities, ensure these are connected and properly used. Use of these devices can reduce dust-related hazards.

4. Power tool use and care

A. Do not force the power tool. Use the correct power tool for your application. The correct power tool will do the job better and safer at the rate for which it was designed.

B. Do not use the power tool if the switch does not turn it on and off. Any power tool that cannot be controlled with the switch is dangerous and must be repaired.

C. Disconnect the plug from the power source and/or the battery pack from the power tool before making any adjustments, changing accessories, or storing power tools. Such preventive safety measures reduce the risk of starting the power tool accidentally.

D. Store idle power tools out of the reach of children and do not allow persons unfamiliar with the power tool or these instructions to operate the power tool. Power tools are dangerous in the hands of untrained users.

E. Maintain power tools. Check for misalignment or binding of moving parts, breakage of parts and any other condition that may affect the power tools operation. If damaged, have the power tool repaired before use. Many accidents are caused by poorly maintained power tools.

F. Keep cutting tools sharp and clean. Properly maintained cutting tools with sharp cutting edges are less likely to bind and are easier to control.

G. Use the power tool, accessories and tool bits etc., in accordance with these instructions and in the manner intended for the particular type of power tool, taking into account the working conditions and the work to be performed. Use of the power tool for operations different from those intended could result in a hazardous situation.

5. Chain Saw Safety

A. Keep all parts of the body away from the saw chain when the chain saw is operating. Before you start the chain saw, make sure the saw chain is not contacting anything. A moment of inattention while operating chain saws may cause entanglement of your clothing or body with the saw chain.

B. Always hold the chain saw with your right hand on the rear handle and your left hand on the front handle. Holding the chain saw with a reversed hand configuration increases the risk of personal injury and should never be done.

C. Hold the power tool by insulated gripping surfaces only, because the saw chain may contact hidden wiring or its own cord. Saw chains contacting a "live" wire may make exposed metal parts of the power tool "live" and could give the operator an electric shock.

D. Wear safety glasses and hearing protection. Further protective equipment for head, hands, legs, and feet is recommended. Adequate protective clothing will reduce personal injury by flying debris or accidental contact with the saw chain.

E. Do not operate a chain saw in a tree. Operation of a chain saw while up in a tree may result in personal injury.

F. Always keep proper footing and operate the chain saw only when standing on a fixed, secure, and level surface. Slippery or unstable surfaces such as ladders may cause a loss of balance or control of the chain saw.

G. When cutting a limb that is under tension be alert for spring back. When the tension in the wood fibre is released the spring loaded limb may strike the operator and/or throw the chain saw out of control.

H Use extreme caution when cutting brush and saplings. The slender material may catch the saw chain and be whipped toward you or pull you off balance.

IMPORTANT SAFETY INSTRUCTIONS

I. Carry the chain saw by the front handle with the chain saw switched off and away from your body. When transporting or storing the chain saw always fit the guide bar cover. Proper handling of the chain saw will reduce the likelihood of accidental contact with the moving saw chain.

G. Follow instructions for lubricating, chain tensioning, and changing accessories. Improperly tensioned or lubricated chain may either break or increase the chance for kickback.

K. Keep handles dry, clean, and free from oil and grease. Greasy, oily handles are slippery causing loss of control.

L. Cut wood only. Do not use chain saw for purpose not intended. For example: do not use chain saw for cutting plastic, masonry or non-wood building materials. Use of the chain saw for operations different than intended could result in a hazardous situation.

Kickback may occur when the nose or tip of the guide bar touches an object, or when the wood closes in and pinches the saw chain in the cut.

Tip contact in some cases may cause a sudden reverse reaction, kicking the guide bar up and back towards the operator.

Pinching the saw chain along the top of the guide bar may push the guide bar rapidly back towards the operator.

Either of these reactions may cause you to lose control of the saw which could result in a serious personal injury. Do not rely exclusively upon the safety devices built into your saw. As a chain saw user, you should take several steps to keep your cutting jobs free from accident or injury.

Kickback is the result of tool misuse and/or incorrect operating procedures or conditions and can be avoided by taking proper precautions as given below:

- Maintain a firm grip, with thumbs and fingers encircling the chain saw handles, with both hands on the saw and position your body and arm to allow you to resist kickback forces. Kickback forces can be controlled by the operator, if proper precautions are taken. Do not let go of the chain saw.

- Do not overreach and do not cut above shoulder height. This helps prevent unintended tip contact and enables better control of the chain saw in unexpected situations.

- Only use replacement bars and chains specified by the manufacturer. Incorrect replacement bars and chains may cause chain breakage and/or kickback.

- Follow the manufacturer's sharpening and maintenance instructions for the saw chain. Decreasing the depth gauge height can lead to increased kickback.

M. Contact of the guide-bar tip with any object should be avoided.

N. Tip contact may cause the guide bar to move suddenly upward and backward, which may cause serious injury.

O. Always use two hands when operating the chainsaw.

Battery tool use and care

a) Recharge only with the charger specified by the manufacturer. A charger that is suitable for one type of battery pack may create a risk of fire when used with another battery pack.

b) Use power tools only with specifically designated battery packs. Use of any other battery packs may create a risk of injury and fire.

c) When battery pack is not in use, keep it away from other metal objects, like paper clips, coins, keys, nails, screws or other small metal objects, that can make a connection from one terminal to another. Shorting the battery terminals together may cause burns or a fire.

d) Under abusive conditions, liquid may be ejected from the battery; avoid contact. If contact accidentally occurs, flush with water. If liquid contacts eyes, additionally seek medical help. Liquid ejected from the battery may cause irritation or burns.

IMPORTANT SAFETY INSTRUCTIONS

6. Service

Have your power tool serviced by a qualified repair person using only identical replacement parts. This will ensure that the safety of the power tool is maintained.

WARNING (Proposition 65)

Some dust created by power sanding, sawing, grinding, drilling, and other construction activities contains chemicals known to cause cancer, birth defects or other reproductive harm. Some examples of these chemicals are:

- lead from lead-based paints
- crystalline silica from bricks and cement and other masonry products, and
- arsenic and chromium from chemically treated lumber.

Your risk of exposure to these chemicals varies depending on how often you do this type of work. To reduce your exposure to these chemicals, work in a well-ventilated area, and work with approved safety equipment, such as dust masks that are specially designed to filter out microscopic particles.

SAVE THESE INSTRUCTIONS

SAFETY INFORMATION

KICKBACK (See Figure 1-2)

⚠ WARNING

Kickback may occur when the moving chain contacts an object at the upper portion of the tip of the guide bar or when the wood closes in and pinches the saw chain in the cut. Contact at the upper portion of the tip of the guide bar can cause the chain to dig into the object and stop the chain for an instant. The result is a lightning fast, reverse reaction which kicks the guide bar up and back toward the operator. If the saw chain is pinched along the top of the guide bar, the guide bar can be driven rapidly back toward the operator. Either of these reactions can cause loss of saw control which can result in serious injury. Do not rely exclusively upon the safety devices built into the saw. As a chain saw user, you should take several steps to keep your cutting jobs free from accident or injury.

- The following precautions should be followed to minimize kickback:
 1. Always grip the saw firmly with both hands. Hold the saw firmly with both hands when the unit is running. Place your right hand on the rear handle and your left hand on the front handle with your thumbs and fingers encircling the chain saw handles. A firm grip together with a stiff left arm will help you maintain control of the saw if kickback occurs.
 2. Make sure that the area in which you are cutting is free from obstructions. Do not let the nose of the guide bar contact a log, branch, fence, or any other obstruction that could be hit while you are operating the saw.
 3. Always cut with the unit running. Fully squeeze the switch trigger and maintain cutting speed.
 4. Use only the replacement guide bars and low kickback chains specified by the manufacturer for the saw.
- With a basic understanding of kickback, you can reduce or eliminate the element of surprise. Sudden surprise contributes to accidents.
- Keep proper footing and balance at all times.
- Do not cut above shoulder height or overreach when cutting.
- Follow the sharpening and maintenance instructions for the saw chain.

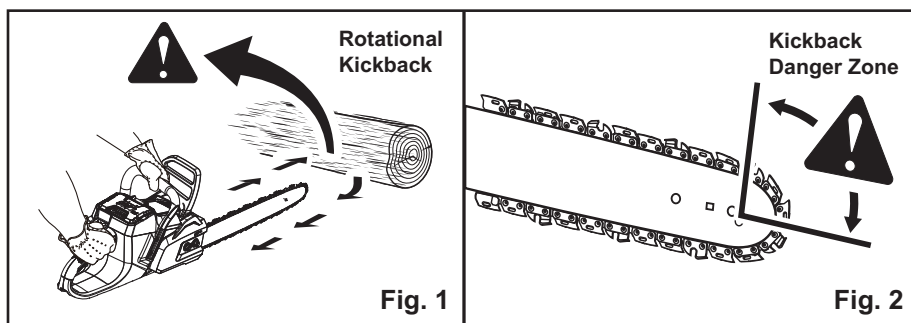

SAFETY INFORMATION

- Push and Pull - This reaction force is always opposite to the direction the chain is moving where wood contact is made. Thus, the operator must be ready to control the PULL when cutting on the bottom edge of the bar, and PUSH when cutting along the top edge. (See Figure 3)

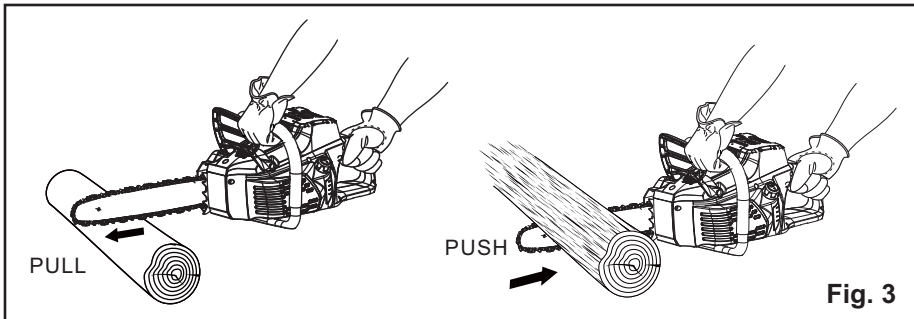

UNDERSTANDING YOUR CHAIN SAW SAFETY DEVICES (See Figure 4)

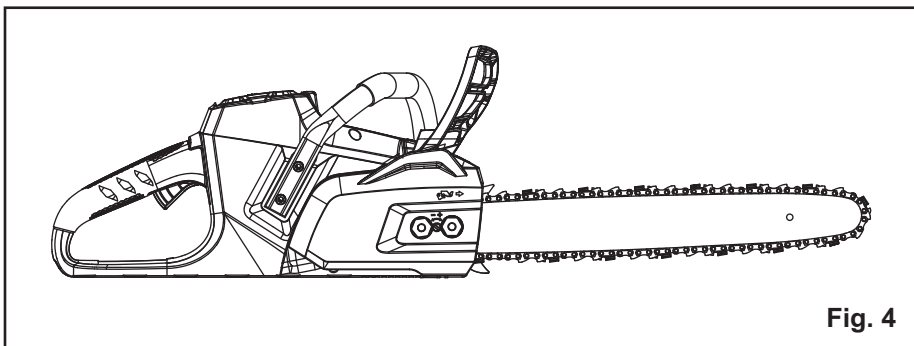













LOW KICKBACK SAW CHAIN

The rakers (depth gauges) ahead of each cutter can minimize the force of a kickback reaction by preventing the cutters from digging in too deeply at the kickback zone. Only use replacement chain that is equivalent to original chain or has been certified as low kickback chain per ANSI B175.1. Low kickback/skip tooth saw chain is a chain that has met the kickback performance requirements of ANSI B175.1 - 1991 (American National Standard for Power Tools - Gasoline-Powered Chain Saws-Safety Requirements) when tested on the representative sample of chain saws below 3.8 c.i.d. specified in ANSI B175.1 - 1991. As saw chains are sharpened during their useful life, they lose some of the low kickback qualities and extra caution should be used.



SYMBOLS

Some of the following symbols may be used on this product. Please study them and learn their meaning. Proper interpretation of these symbols will allow you to operate the product better and safer.

SYMBOLS	DESIGNATION	EXPLANATION
V	Volts	Voltage
A	Amperes	Current
Hz	Hertz	Frequency (cycles per second)
W	Watts	Power
hrs	Hours	Time
Wh	Watt Hours	Energy Storage Capacity
Ah	Amp Hours	Current Capacity
n ₀	No Load Speed	Rational speed, at no load
	Class II Construction	Double-insulated construction
/ min	Per Minute	Revolutions, strokes, surface speed, orbits etc., per minute.
	Lithium-Ion Battery Recycling	Designates that this tool is in compliance with Lithium-Ion battery recycling program requirements.
	Safety Alert Symbol	Precautions that involve your safety.
	Read the Operator's Manual	To reduce the risk of injury, user must read and understand operator's manual before using this product.
	Eye and Hearing Protection	Wear eye and hearing protection when operating this equipment.
	Gloves	Wear non-slip, heavy-duty protective gloves when handling the chain saw and the blade.
	Safety Footwear	Wear non-slip safety footwear when using this equipment.
	Kickback	Tip contact can cause the guide bar to move suddenly upward and backward, which can cause serious injury.
	Operate With Two Hands	Hold and operate the saw properly with both hands.
	One Handed	Do not operate the saw using only one hand.
	Bar Nose Contact	Contact of the guide bar tip with any object should be avoided.
	Keep Bystanders Away	Keep all bystanders at least 50 ft. (15 m) away.
	Wet conditions Alert	Do not expose to rain.

SYMBOLS

The following signal words and meanings are intended to explain the levels of risk associated with this product.

SYMBOL	SIGNAL	MEANING
	DANGER	Indicates an imminently hazardous situation, which, if not avoided, will result in death or serious injury.
	WARNING	Indicates a potentially hazardous situation, which, if not avoided, could result in death or serious injury.
	CAUTION	Indicates a potentially hazardous situation, which, if not avoided, may result in minor or moderate injury.
	CAUTION	(Without Safety Alert Symbol) Indicates a situation that may result in property damage.

SERVICE

Servicing requires extreme care and knowledge and should be performed only by a qualified service technician. For service we suggest you return the product to your nearest **AUTHORIZED SERVICE CENTER** for repair. When servicing, use only identical replacement parts.

W A R N I N G

To avoid serious personal injury, do not attempt to use this product until you have read this Owner's Manual thoroughly and understand it completely. If you do not understand the warnings and instructions in this Owner's Manual, do not use this product. Call the Toll-free Helpline (1-888-909-6757) for assistance.

W A R N I N G



The operation of any power tool can result in foreign objects being thrown into your eyes, which can result in severe eye damage. Before beginning power tool operation, always wear safety goggles or safety glasses with side shields and, when needed, a full face shield. We recommend Wide Vision Safety Mask for use over eyeglasses or standard safety glasses with side shields. Always use eye protection which is marked to comply with ANSI Z87.1.

SAVE THESE INSTRUCTIONS

KNOW YOUR CHAIN SAW

Read this operator's manual and safety rules before operating your chain saw. Compare the illustration in Figure 5 to your chain saw in order to familiarize yourself with the location of various controls and adjustments. Save this manual for future reference.

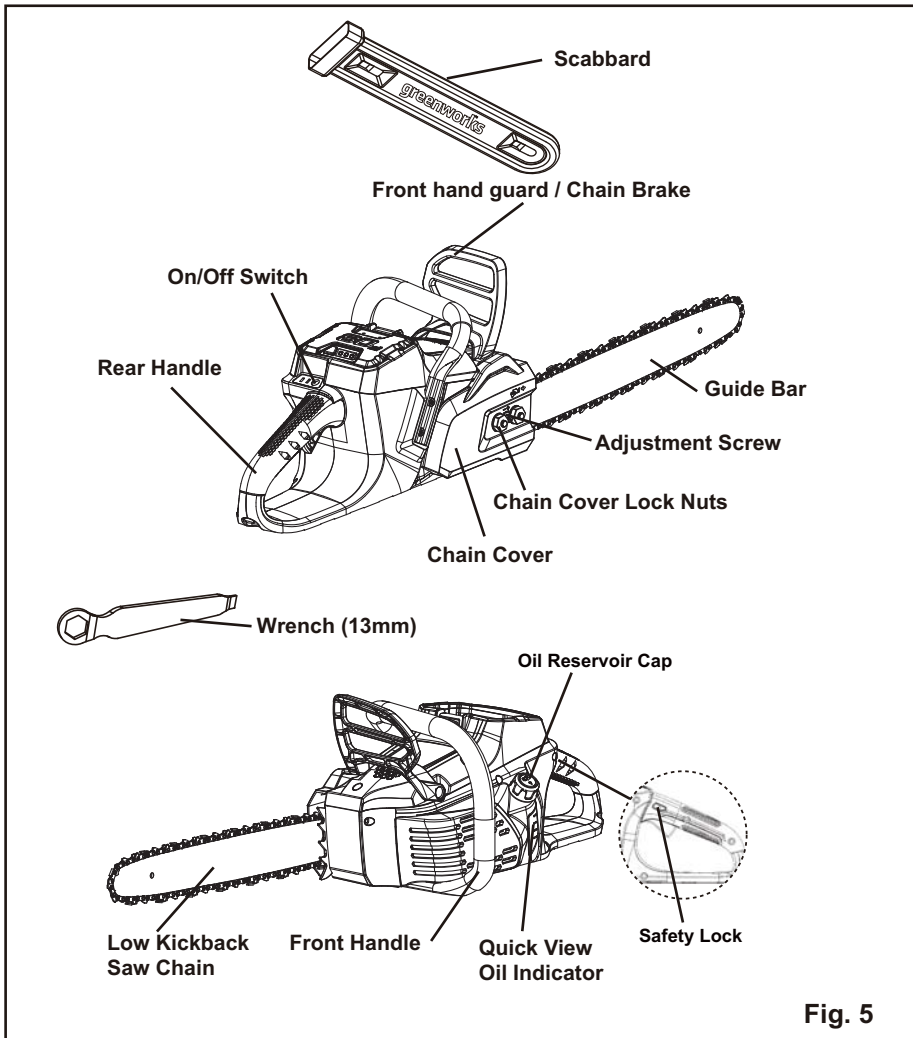

Fig. 5

ASSEMBLY INSTRUCTIONS

UNPACKING

This product has been shipped completely assembled.

- Carefully remove the product and any accessories from the box. Make sure that all items listed in the packing list are included.
- Inspect the product carefully to make sure no breakage or damage occurred during shipping.
- Do not discard the packing material until you have carefully inspected and satisfactorily operated the product.
- If any parts are damaged or missing, please call 1-888-909-6757 for assistance.

PACKING LIST

- Chainsaw
- Scabbard
- Owner's Manual
- Wrench - 13mm (located inside rear handle)
- 80V 2Ah battery (Model# 2901302)
- 80v Charger (Model# 2901402)

W A R N I N G

If any parts are damaged or missing, do not operate this product until the parts are replaced. Failure to heed this warning could result in serious personal injury.

W A R N I N G

Do not attempt to modify this product or create accessories not recommended for use with this product. Any such alteration or modification is misuse and could result in a hazardous condition leading to possible serious personal injury.

W A R N I N G

Do not insert the battery until assembly is complete. Failure to comply could result in accidental starting and possible serious personal injury.

OPERATING YOUR CHAIN SAW

W A R N I N G

Do not allow familiarity with this product to make you careless. Remember that a careless fraction of a second is sufficient to inflict serious injury.

W A R N I N G

Always wear safety goggles or safety glasses with side shields that comply with ANSI Z87.1, when operating power tools. Failure to do so could result in objects being thrown into your eyes, resulting in possible serious injury.

APPLICATIONS

You may use this product for the purposes listed below:

- Basic limbing, felling, and woodcutting
- Removing buttress roots

OPERATING YOUR CHAIN SAW

ADDING BAR AND CHAIN LUBRICANT (See Figure 6)

Use Bar and Chain Lubricant. It is designed for chains and chain oilers, and is formulated to perform over a wide temperature range with no dilution required.

NOTE: Chain saw comes from the factory with no bar and chain oil added. Level should also be checked after every 20 minutes of use and refilled as needed.

- Remove oil cap.
- Carefully pour the bar and chain oil into the tank.
- Wipe off excess oil.
- Check and fill the oil tank when quick view oil indicator is below the MIN. Line.
- Repeat as needed.

NOTE: Do not use dirty, used or otherwise contaminated oils. Damage may occur to the bar or chain.

*NOTE: There is foam inserted inside the oil reservoir to filter dirt and debris from the oil pump. **DO NOT remove the foam.***

NOTE: It is normal for oil to seep from the saw when not in use. To prevent seepage, empty the oil tank after each use then run for one minute. When storing the unit for a long period of time (three months or longer) be sure the chain is lightly lubricated; this will prevent rust on the chain and bar sprocket.

▲ I M P O R T A N T

To preserve natural resources, please recycle or dispose of oil properly. Consult your local waste authority for information regarding available recycling and/disposal options.

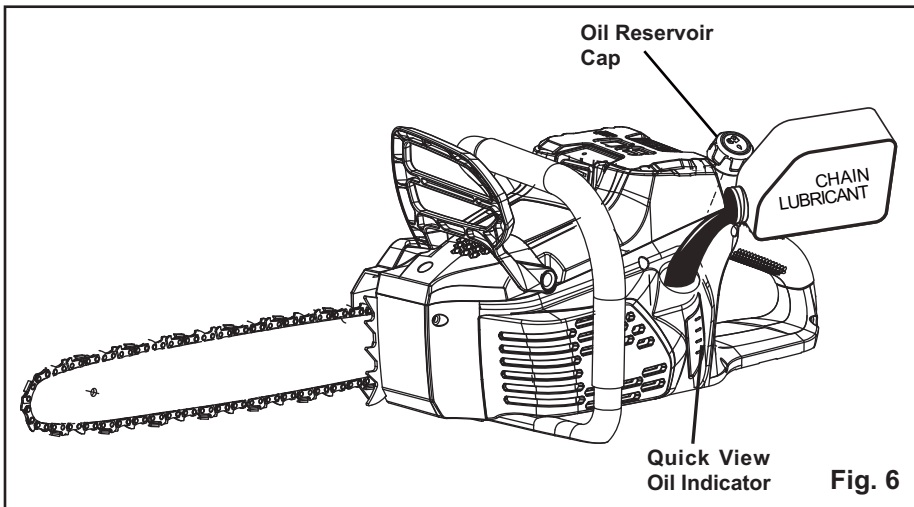

OPERATING YOUR CHAIN SAW

BATTERY PACK (See Figure 7)

▲ I M P O R T A N T

The battery pack is not charged when it is purchased. Before using the chain saw for the first time, place the battery pack in the battery charger and charge it fully. Be sure to read all safety precautions, and follow the instructions in the section entitled Charging Procedure. With regular use, the battery will require shorter charging times. When storing the chain saw for a prolonged period of time, remove the battery. When the chain saw is going to be used again, charge the battery pack for at least a full charging period. This product has no memory effect.

INSTALLING THE BATTERY PACK

- Align the battery pack (3) with the battery compartment on the chain saw.
 - Grasp the chain saw (2) firmly.
 - Push the battery pack into the battery compartment until the latch locks into place.
 - You should hear a "click" once the battery is installed.
-

▲ I M P O R T A N T

This Lithium-ion battery pack is equipped with an internal circuit breaker which will automatically shut off the power to the tool if overloaded. If this occurs, release the trigger to reset the internal circuit breaker.

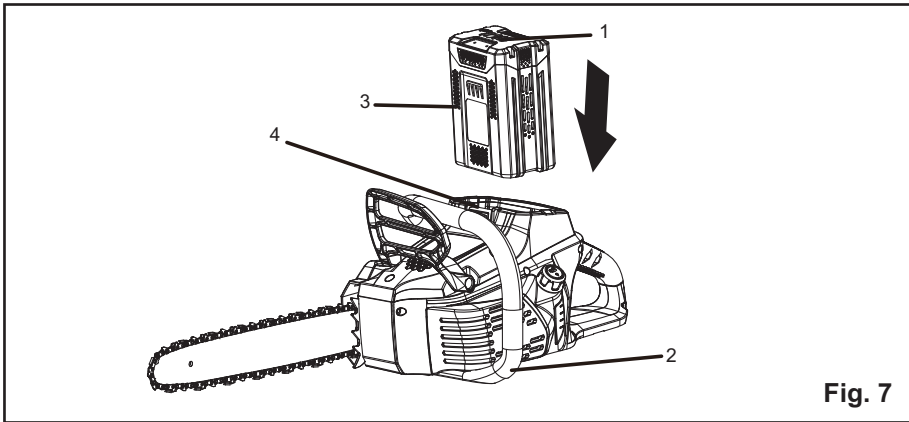

▲ I M P O R T A N T

- Make sure the chain brake is not engaged;
 - Pull back on chain brake guard;
 - Press the O/I button to turn the unit on
-

OPERATING YOUR CHAIN SAW

STARTING AND STOPPING THE CHAIN SAW (See Figure 8)

⚠ WARNING

Keep body to the left of the chain line. Never straddle the saw or chain, or lean over past the chain line.

STARTING THE CHAIN SAW:

- Make sure chain tension is at the desired setting. Refer to Adjusting the Chain Tension in the Maintenance section of this manual.
- Make sure the chain cover lock nuts are tight to the chain cover.
- Make sure no objects or obstructions are in immediate vicinity which could come in contact with the bar and chain.
- Insert the battery into the chain saw. (see figure 7).
- Press the power button to the left of the rear handle. You will hear two beeps signalling the chain saw is active.
- Press in the safety lock. This makes the switch trigger operational.
- Press and hold the switch trigger for continued operation.

STOPPING THE CHAIN SAW:

NOTE: It is normal for the chain to coast to a stop once the trigger switch is released.

- Release the switch trigger to stop the chain saw.
- Upon release of the switch trigger, the safety lock will be automatically reset to the locked position.

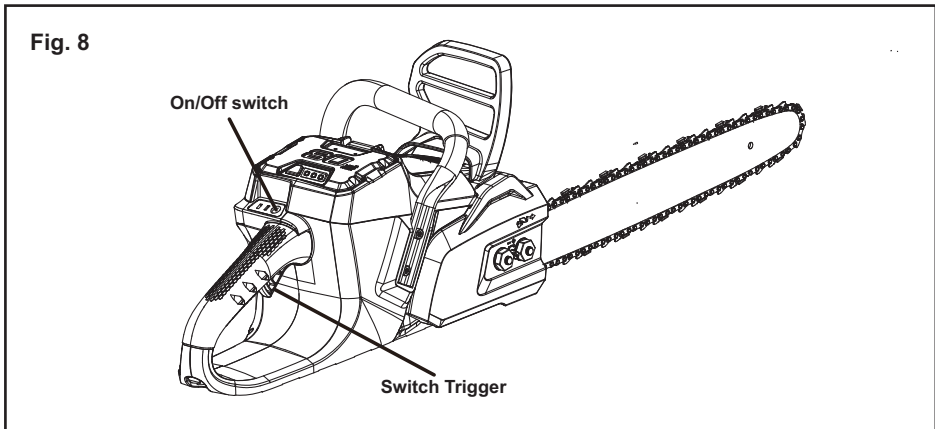

OPERATING YOUR CHAIN SAW

OPERATING THE CHAIN BRAKE (See Figure 9)

Check the operating condition of the chain brake prior to each use.

- Engage the chain brake by rotating your left wrist towards the guard, allowing the back of your hand to engage the brake while the chain is rotating. Be sure to maintain both hands on the saw handles at all times.

⚠ WARNING

If the chain brake does not stop the chain immediately, or if the chain brake will not stay in the run position without assistance, take the saw to an authorized service center for repair prior to use.

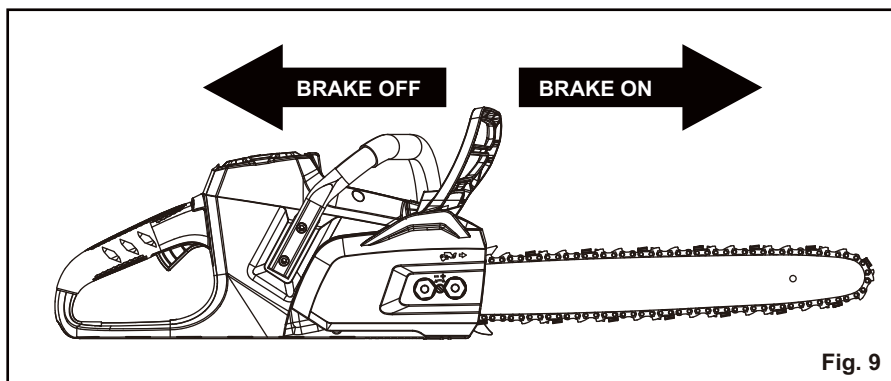

OPERATING YOUR CHAIN SAW

PREPARING FOR CUTTING

PROPER GRIP ON HANDLES (See Figure 10)

See General Safety Rules for appropriate safety equipment.

- Wear non-slip gloves for maximum grip and protection.
- Hold the saw firmly with both hands. Always keep your left hand on the front handle and your right hand on the rear handle so that your body is to the left of the chain line.
- Maintain a proper grip on the saw whenever the motor is running. The fingers should encircle the handle and the thumb is wrapped under the handlebar. This grip is least likely to be broken by a kickback or other sudden reaction of the saw. Any grip in which the thumb and fingers are on the same side of the handle is dangerous because a slight kick of the saw can cause loss of control.

⚠ WARNING

Never use a left-handed (cross-handed) grip or any stance that would place your body or arm across the chain line.

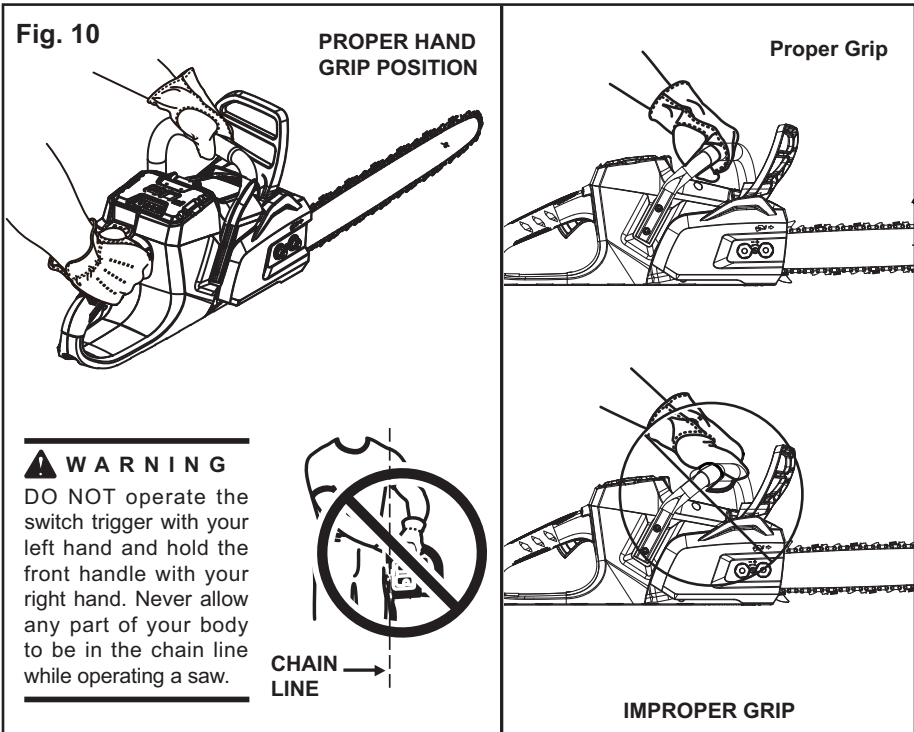

OPERATING YOUR CHAIN SAW

PROPER CUTTING STANCE (See Figure 11)

- Balance your weight with both feet on solid ground.
- Keep left arm with elbow locked in a “straight arm” position to withstand any kickback force.
- Keep your body to the left of the chain line.
- Keep your thumb on underside of handlebar.

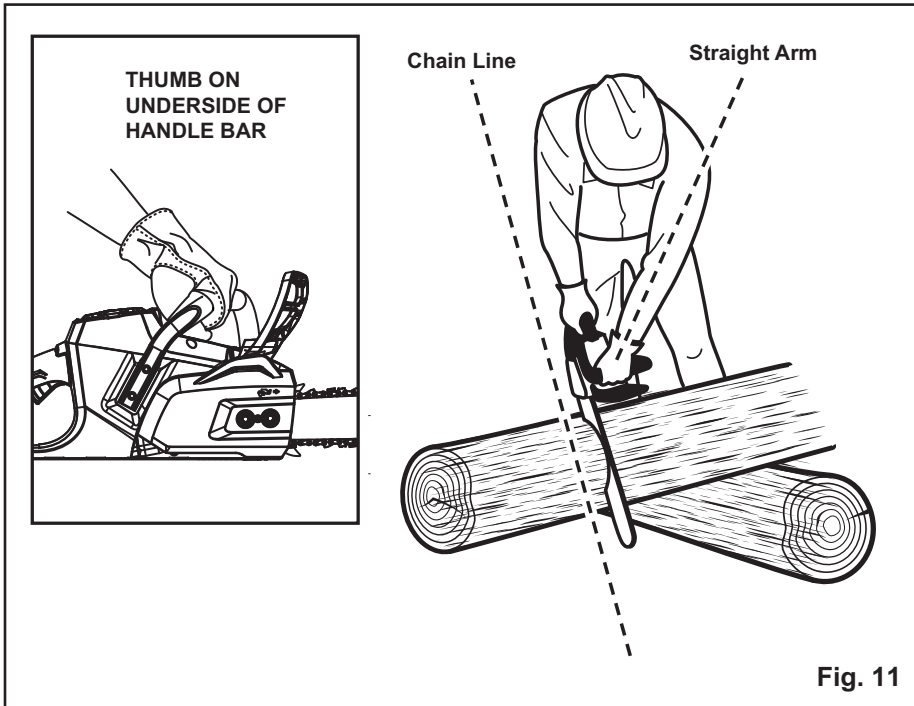

OPERATING YOUR CHAIN SAW

BASIC OPERATING/CUTTING PROCEDURES

Practice cutting a few small logs using the following technique to get the “feel” of using the saw before you begin a major sawing operation.

- Take the proper stance in front of the wood with the saw idling.
- Press the safety lock and squeeze the switch trigger then release safety lock and let the chain accelerate to full speed before entering the cut.
- Begin cutting with the saw against the log.
- Keep the unit running the entire time you are cutting, maintain a steady speed.
- Allow the chain to cut for you; exert only light downward pressure. Forcing the cut could result in damage to the bar, chain, or motor.
- Release the switch trigger as soon as the cut is completed, allowing the chain to stop. If you run the saw without a cutting load, unnecessary wear can occur to the chain, bar, and unit.
- Do not put pressure on the saw at the end of the cut.

WORK AREA PRECAUTIONS (See Figure 12)

- Cut only wood or materials made from wood; no sheet metal, no plastics, no masonry, no non-wood building materials.
- Never allow children to operate the saw. Allow no person to use this chain saw who has not read this operator’s manual or received adequate instructions for the safe and proper use of this chain saw.
- Keep everyone – helpers, bystanders, children, and animals – a SAFE DISTANCE from the cutting area. During felling operations, the safe distance should be a least twice the height of the largest trees in the felling area. During bucking operations, keep a minimum distance of 15’ (4.6 m) between workers.
- Always cut with both feet on solid ground to prevent being pulled off balance.
- Do not cut above chest height as a saw held higher is difficult to control against kickback forces.
- Do not fell trees near electrical wires or buildings. Leave this operation for professionals.
- Cut only when visibility and light are adequate for you to see clearly.



Fig. 12

OPERATING YOUR CHAIN SAW

FELLING TREES

HAZARDOUS CONDITIONS

W A R N I N G

Do not fell trees during periods of high wind or heavy precipitation. Wait until the hazardous weather has ended.

When felling a tree, it is important that you heed the following warnings to prevent possible serious injury.

- Do not cut down trees having an extreme lean or large trees with rotten limbs, loose bark, or hollow trunks. Have these trees pushed or dragged down with heavy equipment, then cut them up.
- Do not cut trees near electrical wires or buildings.
- Check the tree for damaged or dead branches that could fall and hit you during felling.
- Periodically glance at the top of the tree during the backcut to assure the tree is going to fall in the desired direction.
- If the tree starts to fall in the wrong direction, or if the saw gets caught or hung up during the fall, leave the saw and save yourself!

OPERATING YOUR CHAIN SAW

PROPER PROCEDURE FOR TREE FELLING (See Figure 13-16)

- Felling a tree — When bucking and felling operations are being performed by two or more persons, at the same time, the felling operation should be separated from the bucking operation by a distance of at least twice the height of the tree being felled. Trees should not be felled in a manner that would endanger any person, strike any utility line or cause any property damage. If the tree does make contact with any utility line, the utility company should be notified immediately.
- Operator should keep on the uphill side of terrain as the tree is likely to roll or slide after it is felled.
- Pick your escape route (or routes in case the intended route is blocked). Clear the immediate area around the tree and make sure there are no obstructions in your planned path of retreat. Clear the path of safe retreat approximately 135° from the planned line of fall.
- Consider the force and direction of the wind, the lean and balance of the tree, and the location of large limbs. These things influence the direction in which the tree will fall. Do not try to fell a tree along a line different from its natural line of fall.
- Remove dirt, stones, loose bark, nails, staples, and wire from the tree where felling cuts are to be made.
- Notched Undercut. Cut a notch about 1/3 the diameter of the trunk in the side of the tree. Make the notch cuts so they intersect at a right angle to the line of fall. This notch should be cleaned out to leave a straight line. To keep the weight of the wood off the saw, always make the lower cut of the notch before the upper cut.
- Felling Backcut. As the felling cut gets close to the hinge the tree should begin to fall. If there is any chance the tree may not fall in the desired direction or it may rock back and bind the saw chain, stop cutting before the felling cut is complete and use wedges of wood, plastic or aluminum to open the cut and drop the tree along its desired line of fall. Make the backcut level and horizontal, and at a minimum of 2" (5 cm) above the horizontal cut of the notch.

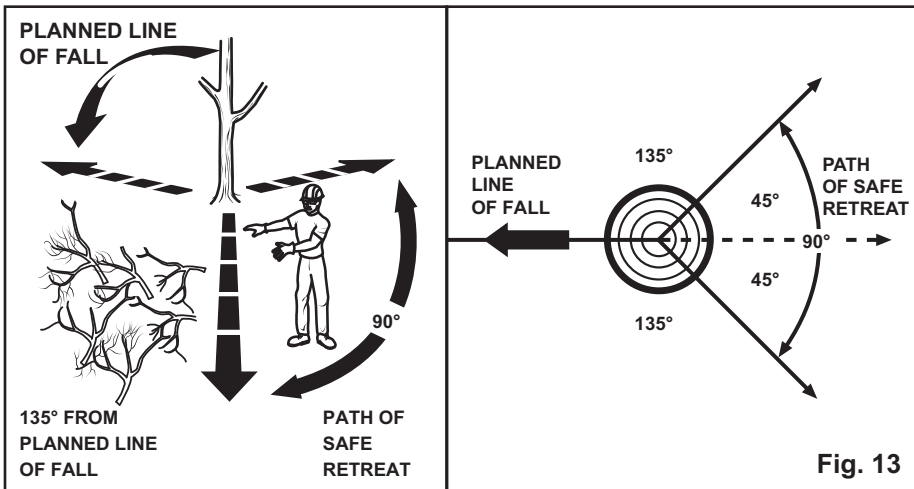
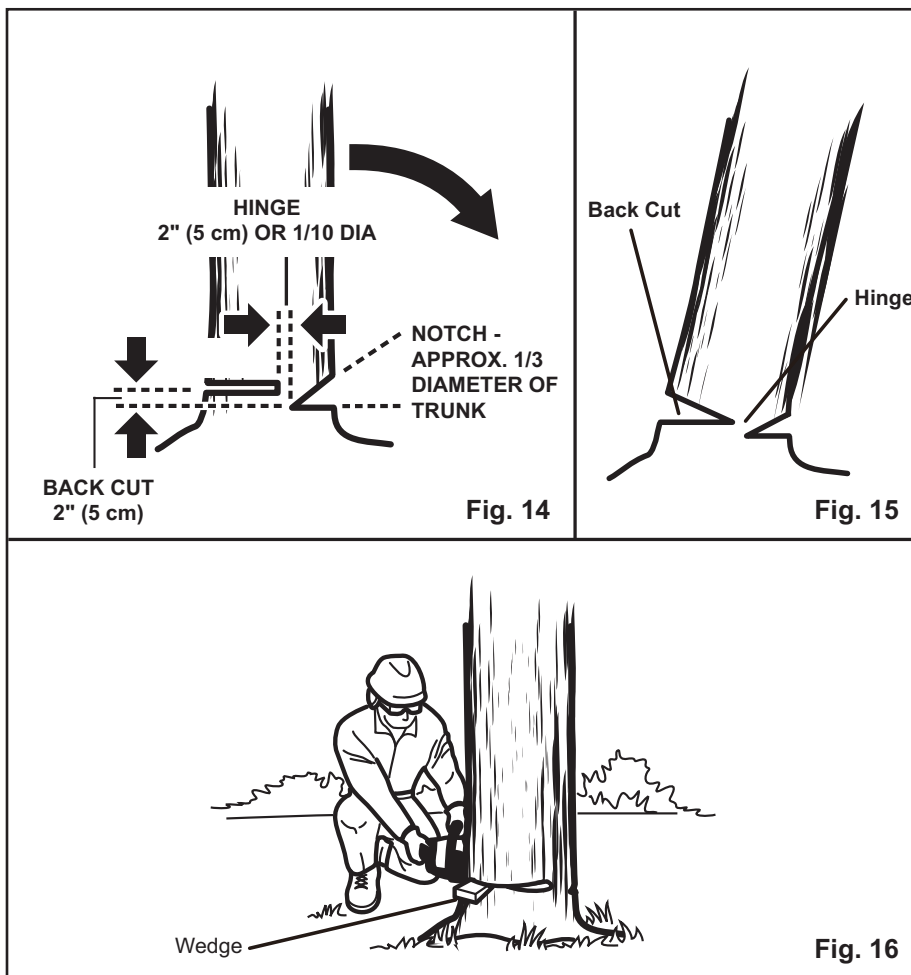

Fig. 13

OPERATING YOUR CHAIN SAW

NOTE: Never cut through to the notch. Always leave a band of wood between the notch and back cut (approximately 2" (5 cm) or 1/10 the diameter of the tree). This is called "hinge" or "hingewood." It controls the fall of the tree and prevents slipping or twisting or shoot back of the tree off the stump.

- On large diameter trees, stop the back cut before it is deep enough for the tree to either fall or settle back on the stump. Then insert soft wooden or plastic wedges into the cut so they do not touch the chain. Drive wedges in, little by little, to help jack the tree over.
- As tree starts to fall, stop the chain saw and put it down immediately. Retreat along the cleared path, but watch the action in case something falls your way.



OPERATING YOUR CHAIN SAW

REMOVING BUTTRESS ROOTS (See Figure 17)

A buttress root is a large root extending from the trunk of the tree above the ground. Remove large buttress roots prior to felling. Make the horizontal cut into the buttress first, followed by the vertical cut. Remove the resulting loose section from the work area. Follow the correct tree felling procedure as stated in Proper Procedure For Tree Felling after you have removed the large buttress roots.

BUCKING (See Figure 18)

Bucking is the term used for cutting a fallen tree to the desired log length.

- Always make sure your footing is secure and your weight is distributed evenly on both feet.
- Cut only one log at a time.
- Support small logs on a saw horse or another log while bucking.
- Keep a clear cutting area. Make sure that no objects can contact the guide bar nose and chain during cutting, this can cause kickback. Refer to Kickback earlier in this manual.
- When bucking on a slope, always stand on the uphill side of the log. To maintain complete control of the chain saw when cutting through the log, release the cutting pressure near the end of the cut without relaxing your grip on the chain saw handles. Do not let the chain contact the ground. After completing the cut, wait for the saw chain to stop before you move the chain saw. Always stop the motor before moving from tree to tree.

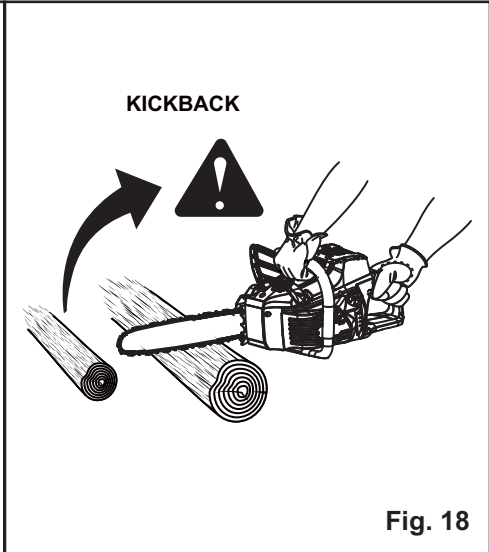
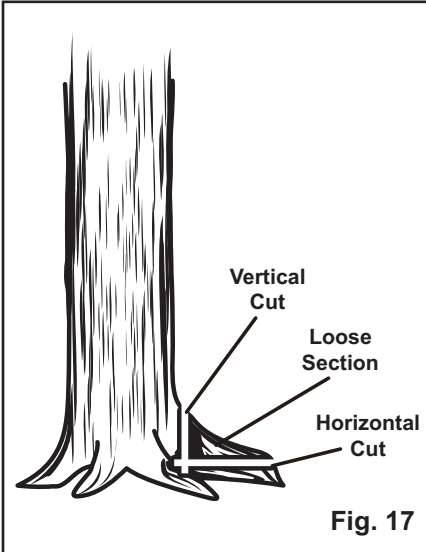

OPERATING YOUR CHAIN SAW

BUCKING WITH A WEDGE (See Figure 19)

If the wood diameter is large enough for you to insert a soft bucking wedge without touching the chain, you should use the wedge to hold the cut open to prevent pinching.

BUCKING LOGS UNDER STRESS (See Figure 20)

Make the first bucking cut 1/3 of the way through the log and finish with a 2/3 cut on the opposite side. As you cut the log, it will tend to bend. The saw can become pinched or hung in the log if you make the first cut deeper than 1/3 of the diameter of the log. Give special attention to logs under stress to prevent the bar and chain from pinching.

OVERBUCKING (See Figure 21)

Begin on the top side of the log with the bottom of the saw against the log; exert light pressure downward. Note that the saw will tend to pull away from you.

UNDERBUCKING (See Figure 22)

Begin on the under side of the log with the top of the saw against the log; exert light pressure upward. During under bucking, the saw will tend to push back at you. Be prepared for this reaction and hold the saw firmly to maintain control.

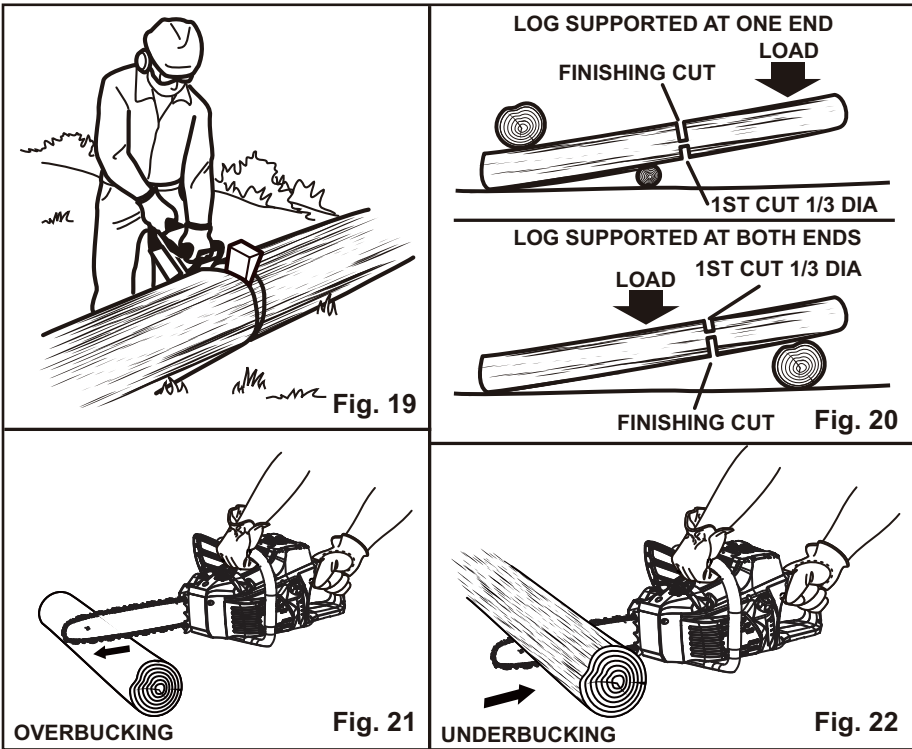

OPERATING YOUR CHAIN SAW

LIMBING (See Figure 23)

Limbing is removing branches from a fallen tree.

- Work slowly, keeping both hands on the chain saw with a firm grip. Always make sure your footing is secure and your weight is distributed evenly on both feet.
- Leave the larger support limbs under the tree to keep the tree off the ground while cutting.
- Limbs should be cut one at a time. Remove the cut limbs from the work area often to help keep the work area clean and safe.
- Branches under tension should be cut from the bottom up to avoid binding the chain saw.
- Keep the tree between you and the chain saw while limbing. Cut from the side of the tree opposite the branch you are cutting.

PRUNING (See Figure 24)

Pruning is trimming limbs from a live tree.

- Work slowly, keeping both hands on the chain saw with a firm grip. Always make sure your footing is secure and your weight is distributed evenly on both feet.
- Do not cut from a ladder, this is extremely dangerous. Leave this operation for professionals.
- Do not cut above chest height as a saw held higher is difficult to control against kickback.
- When pruning trees it is important not to make the finishing cut next to the main limb or trunk until you have cut off the limb further out to reduce the weight. This prevents stripping the bark from the main member.
- Underbuck the branch 1/3 through for your first cut.
- Your second cut should overbuck to drop the branch off.
- Now make your finishing cut smoothly and neatly against the main member so the bark will grow back to seal the wound.

⚠ WARNING

If the limbs to be pruned are above chest height, hire a professional to perform the pruning.

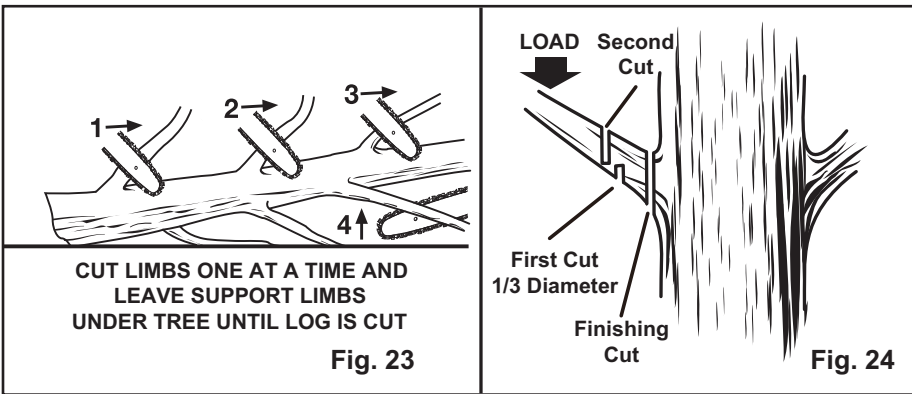

OPERATING YOUR CHAIN SAW

CUTTING SPRINGPOLES (See Figure 25)

A springpole is any log, branch, rooted stump, or sapling which is bent under tension by other wood so that it springs back if the wood holding it is cut or removed. On a fallen tree, a rooted stump has a high potential of springing back to the upright position during the bucking cut to separate the log from the stump. Watch out for springpoles — they are dangerous.

▲ WARNING

Springpoles are dangerous and could strike the operator, causing the operator to lose control of the chain saw. This could result in severe or fatal injury to the operator.

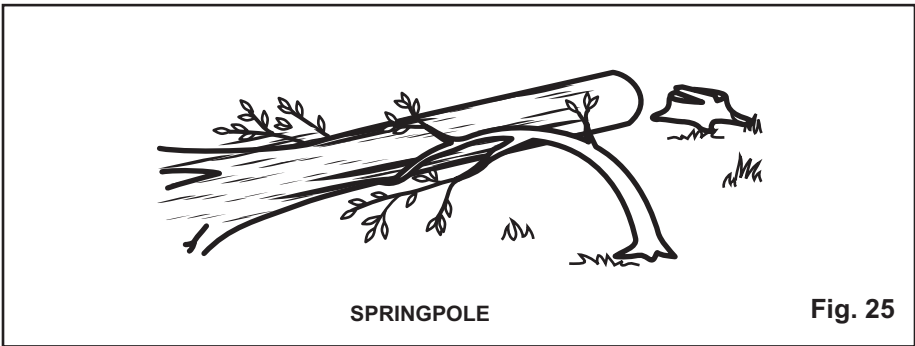

MAINTENANCE

W A R N I N G

When servicing, use only identical replacement parts. Use of any other parts may create a hazard or cause product damage.

W A R N I N G

Always wear safety goggles or safety glasses with side shields during power tool operation or when blowing dust. If operation is dusty, also wear a dust mask.

GENERAL MAINTENANCE

Avoid using solvents when cleaning plastic parts. Most plastics are susceptible to damage from various types of commercial solvents and may be damaged by their use. Use clean cloths to remove dirt, dust, lubricant, grease, etc. firmly to maintain control.

W A R N I N G

Do not at any time let brake fluids, gasoline, petroleum-based products, penetrating oils, etc., come in contact with plastic parts. Chemicals can damage, weaken, or destroy plastic, which may result in serious personal injury.

LUBRICATION

All of the bearings in this product are lubricated with a sufficient amount of high grade lubricant for the life of the unit under normal operating conditions. Therefore, no further lubrication is required.

REPLACING THE GUIDE BAR AND CHAIN *(See Figure 25-31)*

D A N G E R

Never start the motor before installing the guide bar, chain, chain cover, and chain cover lock nuts. Without all these parts in place, the clutch can fly off or explode, exposing the user to possible serious injury.

W A R N I N G

To avoid serious personal injury, read and understand all the safety instructions in this section.

W A R N I N G

Before performing any maintenance, make sure the battery is removed. Failure to heed this warning could result in serious personal injury.

MAINTENANCE

CAUTION

Always wear gloves when handling the bar and chain; these components are sharp and may contain burrs.

- Remove the battery from the chain saw.
- Remove the supplied wrench from the rear handle.
- Remove the two chain cover lock nuts from the chain cover by rotating them counterclockwise with the wrench.

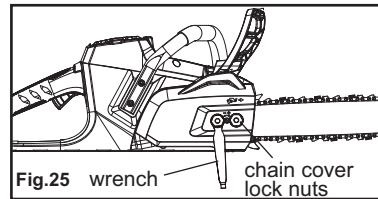

- Remove the chain cover from the mounting surface.
- The bar and chain can now be removed by lifting it away from the main body of the saw and releasing the chain from the sprocket.
- Remove the old chain from the bar.

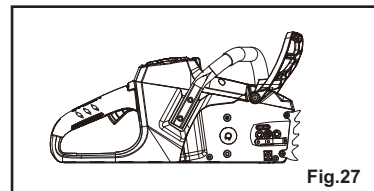
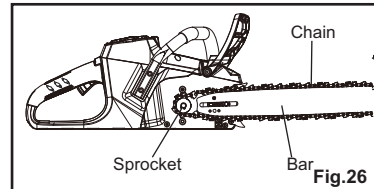

- Lay out the new saw chain in a loop and straighten any kinks. The cutters should face in the direction of chain rotation. If they face backwards, turn the loop over.
- Place the chain drive links into the bar groove.

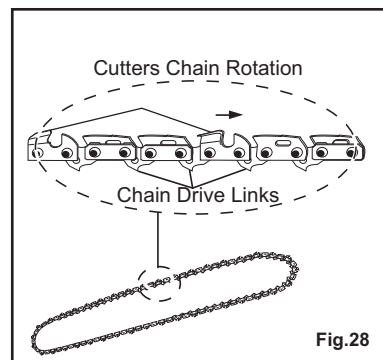

MAINTENANCE

Note: Make certain of direction of the chain.

- Position the chain so there is a loop at the back of the bar.
- Hold the chain in position on the bar and place the loop around the sprocket.
- Fit the bar flush against the mounting surface so that the bar studs are in the long slot of the bar. Ensure that the chain is over the sprocket.

Note: When placing the bar on the bar studs, ensure that the adjusting pin is in the chain tension pin hole.

- Replace the chain cover.
- Remove all slack from the chain by turning the chain adjustment screw clockwise until the chain seats snugly against the bar with the drive links in the bar groove.

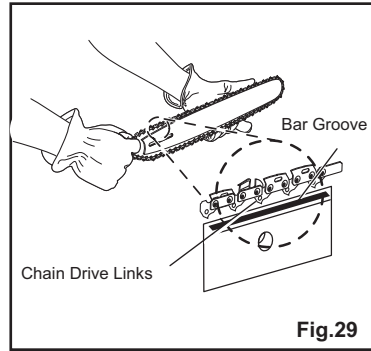

- Lift the tip of the guide bar up to check for sag.
- Release the tip of the guide bar and turn the chain adjustment screw 1/2 turn clockwise. Repeat this process until sag does not exist.
- Hold the tip of the guide bar up and tighten the chain cover lock nuts by turning them with the wrench. The chain is correctly tensioned when there is no sag on the underside of the guide bar, the chain is snug, but it can be turned by hand without binding.

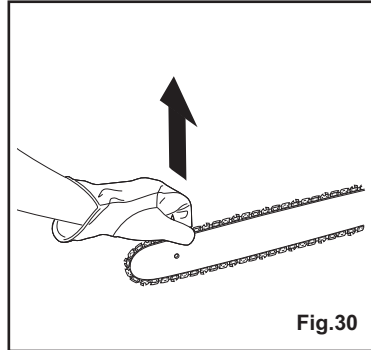

Note: If the chain is too tight, it will not rotate. Loosen the chain cover lock nuts slightly and turn the chain adjustment screw 1/4 turn counterclockwise. Lift the tip of the guide bar up and retighten the chain cover lock nuts. Ensure that the chain will rotate without binding.

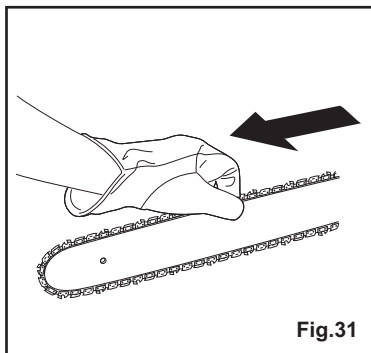

MAINTENANCE

ADJUSTING THE CHAIN TENSION (see figure 32-34)

WARNING

Never touch or adjust the chain while the motor is running. The saw chain is very sharp. Always wear protective gloves when performing maintenance on the chain.

- Loosen the chain cover lock nuts with the supplied wrench. The chain cover lock nuts do not have to be completely removed in order to adjust the chain tension.

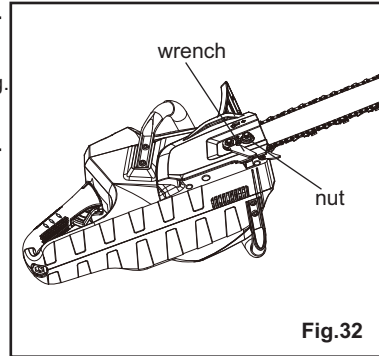

- Rotate the chain adjustment screw clockwise to increase the chain tension and rotate counterclockwise to decrease the chain tension.
- Once the chain is at the desired tension, tighten the chain cover lock nuts.

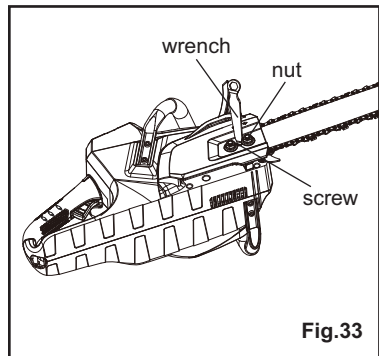

Note: During normal saw operation, the temperature of the chain increases. The drive links of a correctly tensioned warm chain will hang approximately 1/16 in. (1,58 mm) out of the bar groove.

Note: New chains tend to stretch; check the chain tension frequently and tension as required.

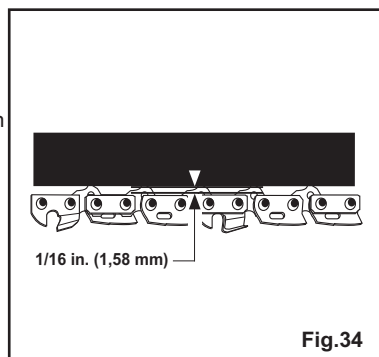

MAINTENANCE

CAUTION

A chain tensioned while warm may be too tight upon cooling. Check the “cold tension” before next use. Never tension a warm chain before storing as chains shrink when cool. This can damage the chain, bar and saw.

CHAIN MAINTENANCE (see figure 35)

Use only a low-kickback chain on this saw. This fast-cutting chain provides kickback reduction when properly maintained. For smooth and fast cutting, maintain the chain properly. The chain requires sharpening when the wood chips are small and powdery, the chain must be forced through the wood during cutting, or the chain cuts to one side. During maintenance of the chain, consider the following:

- Improper filing angle of the side plate can increase the risk of severe kickback.
- Raker (depth gauge) clearance:
 - Too low– increases the potential for kickback.
 - Not low enough– decreases cutting ability.
- If the cutter teeth hit hard objects such as nails or stones, or are abraded by mud or sand on the wood, have an authorized service center sharpen the chain.

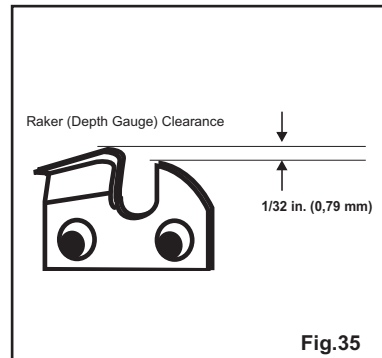

Note:

- Inspect the drive sprocket for wear or damage when replacing the chain. Have the drive sprocket replaced by an authorized service center if there are any signs of wear or damage.
- If you do not fully understand the correct procedure for sharpening the chain after reading the instructions that follow, have the saw chain sharpened by an authorized service center or replace with a recommended low-kickback chain.

MAINTENANCE

SHARPENING THE CUTTERS (See *Figure 36-39*)

Be careful to file all cutters to the specified angles and to the same length, as fast cutting can be obtained only when all cutters are uniform.

CAUTION

Make sure the battery is removed from the chain saw before you work on the saw.

WARNING

The saw chain is very sharp. Always wear protective gloves when performing maintenance to the chain to prevent serious personal injury.

- Tension the chain prior to sharpening. Refer to Adjusting The Chain Tension.
- Use a 5/32" (4 mm) diameter round file and holder. Do all of your filing at the midpoint of the bar.
- Keep the file level with the top plate of the tooth. Do not let the file dip or rock.
- Using light but firm pressure. Stroke towards the front corner of the tooth.
- Lift the file away from the steel on each return stroke.
- Put a few firm strokes on every tooth. File all left hand cutters in one direction. Then move to the other side and file the right hand cutters in the opposite direction.
- Remove filings from the file with a wire brush.

CAUTION

A dull or improperly sharpened chain can cause excessive motor speed during cutting, which may result in severe motor damage.

WARNING

Improper chain sharpening increases the potential of kickback.

WARNING

Failure to replace or repair a damaged chain can cause serious injury.

MAINTENANCE

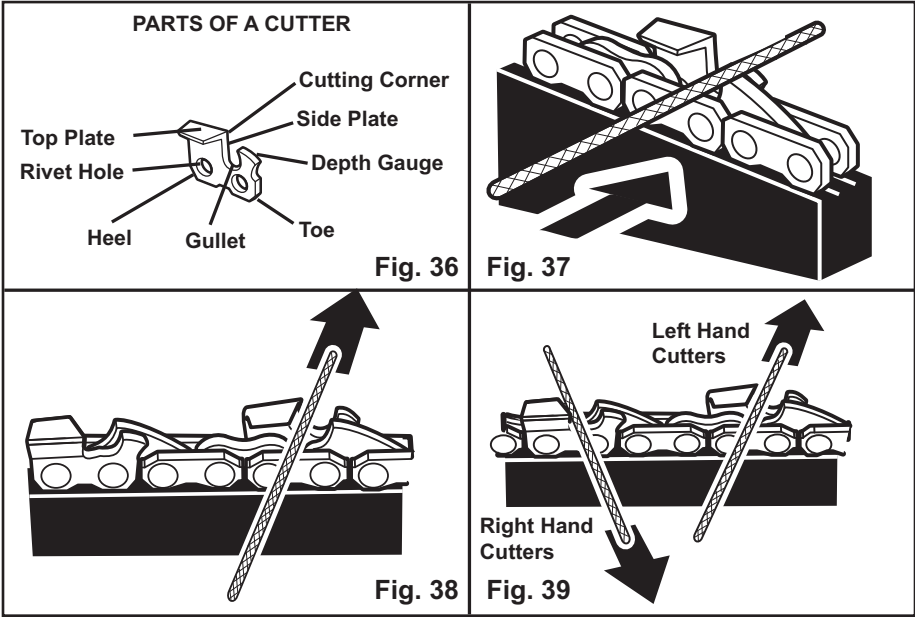

TOP PLATE FILING ANGLE (See Figure 40)

- CORRECT 30° – file holders are marked with guide marks to align file properly to produce correct top plate angle.
- LESS THAN 30° – for cross cutting.
- MORE THAN 30° – feathered edge dulls quickly.

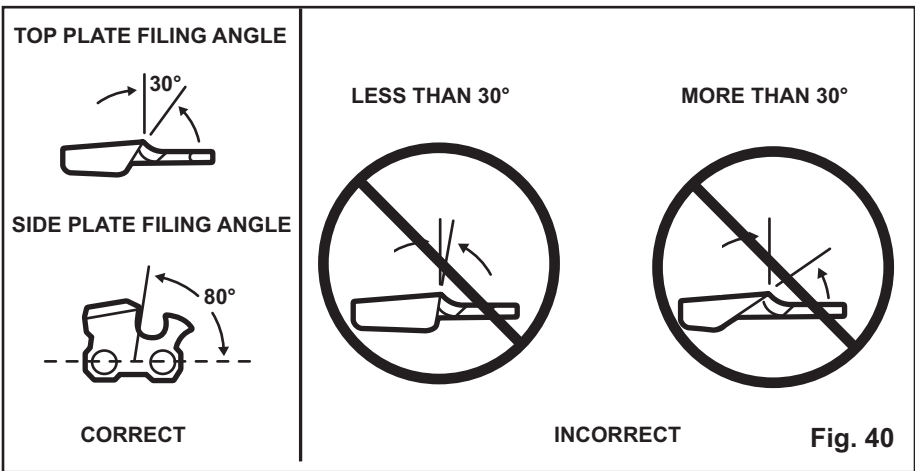

MAINTENANCE

SIDE PLATE ANGLE (See Figure 41)

- CORRECT 80° – Produced automatically if you use the correct diameter file in the file holder.
- HOOK – “Grabs” and dulls quickly; increases the potential of KICKBACK. Results from using a file with a diameter too small or a file held too low.
- BACKWARD SLOPE – Needs too much feed pressure; causes excessive wear to the bar and chain. Results from using a file with a diameter too large or file held too high.

SIDE PLATE ANGLE (See Figure 42-44)

- Maintain the depth gauge at a clearance of 1/32" (0.6 mm) Use a depth gauge tool for checking the depth gauge clearances.
- Every time the chain is filed, check the depth gauge clearance.
- Use a flat file and a depth gauge jointer to lower all gauges uniformly. Use a 1/32" (0.6 mm) depth gauge jointer. After lowering each depth gauge, restore original shape by rounding the front.
- Depth gauges must be adjusted with the flat file in the same direction the adjoining cutter was filed with the round file.
- Use care not to contact cutter face with flat file when adjusting depth gauges.

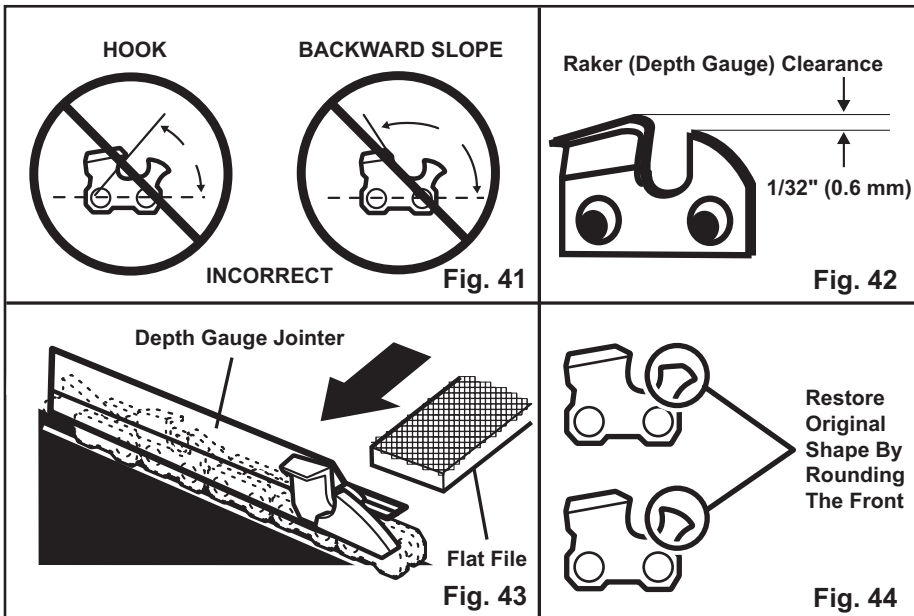

MAINTENANCE

MAINTAINING THE GUIDE BAR (See Figure 45)

Every week of use, reverse the guide bar on the saw to distribute the wear for maximum bar life. The bar should be cleaned every day of use and checked for wear and damage. Feathering or burring of the bar rails is a normal process of bar wear. Such faults should be smoothed with a file as soon as they occur. A bar with any of the following faults should be replaced:

- Wear inside the bar rails that permits the chain to lay over sideways
- Bent guide bar
- Cracked or broken rails
- Spread rails

Lubricate guide bars weekly with a sprocket at their tip. Using a grease syringe, lubricate weekly in the lubricating hole. Turn the guide bar and check that the lubrication holes and chain groove are free from impurities.

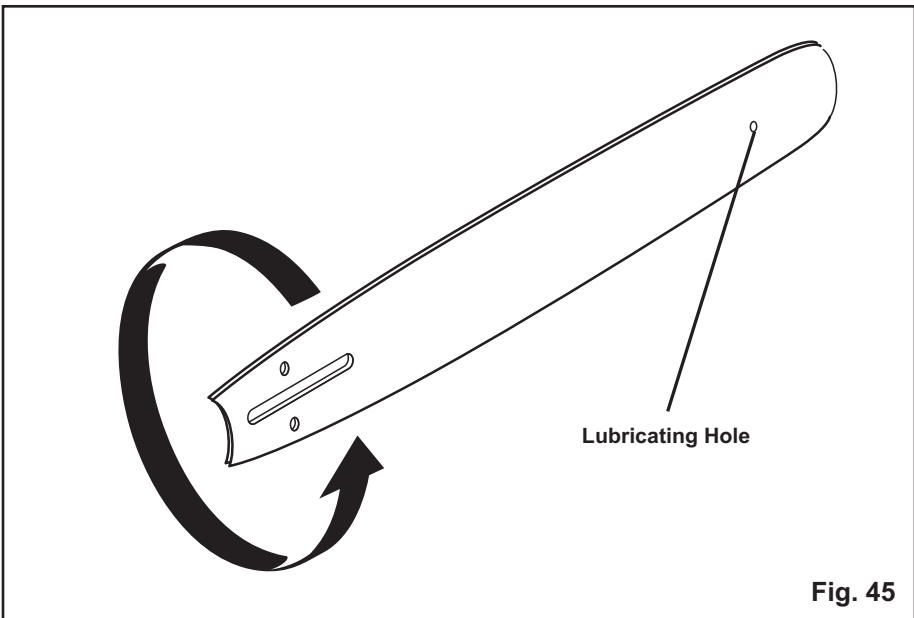

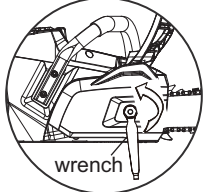

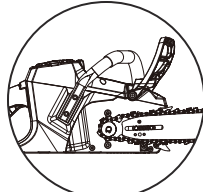

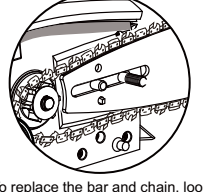
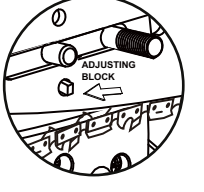
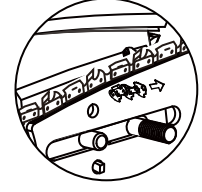
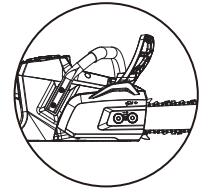
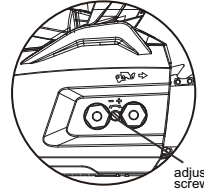

Fig. 45

STORAGE

- Ensure the battery is removed from the chain saw.
- Wipe any debris off of the chain saw, including built up wood chips under the chain cover.
- Store in a dry cool place out of the reach of children.
- Store with the scabbard on to prevent damage to the chain and potential damage to other.

MAINTENANCE

Quick reference of Chain&Bar assembly (Chain Tension)

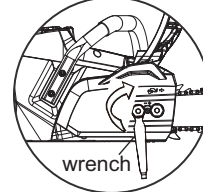
 <p>wrench</p> <p>1. To remove the chain cover, loosen the two chain cover lock nuts by turning them counterclockwise with the supplied wrench.</p>	 <p>2. Then loosen the adjustment screw 2 or 3 turns.</p>	 <p>3. Now totally remove the chain cover lock nuts and remove the chain cover.</p>
 <p>4. The bar and chain can now be removed by lifting it away from the main body of the saw and releasing the chain from the drive pulley.</p>	 <p>5. The chainsaw can now be cleaned with a brush and or rag to remove sawdust and oil.</p>	 <p>6. To replace the bar and chain, loop the chain over the drive pulley and place the bar against the center alignment groove.</p>
 <p>ADJUSTING BLOCK</p> <p>7. Ensure that the adjusting block is located in the tensioning hole on the chain bar.</p>	 <p>8. And that the rubber block and chain bar are free from oil, as this helps to keep tension on the chain.</p>	 <p>9. Replace the chain cover and chain cover lock nuts knob, but do not tighten.</p>
 <p>adjustment screw</p> <p>10. Turn the adjustment screw Clockwise to tighten the chain.</p>	 <p>11. Until there is enough play that the chain can be pulled away from the bar, but not so much that the runners can be pulled out of the bar.</p>	 <p>wrench</p> <p>12. Once you have the correct tension, fully tighten the chain cover lock nuts.</p>

NOTE:

- Chains stretch with use, check and tension often.
- Never tension a warm chain before storing, as chains shrink when cool, this can damage chain, bar and saw.

ENVIRONMENTALLY SAFE BATTERY DISPOSAL

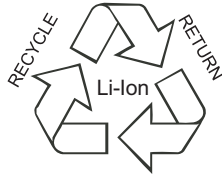

The batteries used in this chainsaw's battery pack contain the following toxic and corrosive material: LITHIUM-ION.

⚠ WARNING

Toxic materials must be disposed of in a specified manner in order to prevent contamination of the environment. Before disposing of damaged or worn out Lithium-Ion battery packs, contact your local waste disposal agency or the local Environmental Protection Agency for information and specific instructions. Take the batteries to a local recycling and/or disposal centre that is certified for disposal. If the battery pack cracks or breaks, whether it leaks or not, do not recharge it and do not use it. Dispose of it and replace it with a new battery pack. **DO NOT ATTEMPT TO REPAIR IT!**

Follow these instructions in order to avoid injury and the risk of fire, explosion, or electric shock, and to avoid damage to the environment:

- Cover the battery's terminals with heavy-duty adhesive tape.
- Do not attempt to remove or destroy any of the components of the battery pack.
- Do not attempt to open the battery pack.
- If a leak develops, the electrolytes that are released are corrosive and toxic. Do not get the solution in the eyes or on the skin, and do not swallow it.
- Do not place batteries in regular household trash.
- DO NOT incinerate batteries.
- DO NOT place batteries where they will become part of any waste landfill or municipal solid waste stream.
- Dispose of batteries at a certified recycling or disposal centre.

TROUBLESHOOTING

PROBLEM	POSSIBLE CAUSE	SOLUTION
Bar and chain running hot and smoking.	Check chain tension for overtightened condition. Chain oil tank empty.	Loosen the chain if it is too tight. Refer to Adjusting the Chain Tension earlier in this manual. Check oil tank.
Motor runs, but chain is not rotating.	Chain tension too tight. Check guide bar and chain assembly Check guide bar and chain for damage.	Loosen the chain if it is too tight. Refer to Adjusting the Chain Tension earlier in this manual. Refer to Replacing the Bar and Chain earlier in this manual. Inspect guide bar and chain for damage.
Motor runs, chain rotates but does not cut.	Dull chain. Chain on backwards.	Sharpen or replace the chain. Reverse direction of chain.
Beep sound is heard while attempting to start.	Battery requires charging.	Charge the battery. Refer to the battery and charger manual for correct charging procedures.
Chain saw stops while cutting.	Chain saw is overloaded.	Release the trigger to reset the internal circuit breaker. Do not force the chain saw.